



# EUROLIFT

# Z61/3S

SOLLEVATORE ELETTOIDRAULICO  
A DUE COLONNE

TWO COLUMNS ELECTRO-HYDRAULIC AUTO-LIFT  
ÉLÉVATEUR ÉLECTROHYDRAULIQUE À DEUX COLONNES  
ELEKTROHYDRAULISCHE ZWEI SAULEN-HEBEBUEHN  
ELEVADOR ELECTROHIDRÁULICO DE DOS COLUMNAS



## Z61/3S

### ZAVAGLI

Via Malpasso 17 - Loc. Vacchereccia - 52022 Cavriglia (Arezzo)

Tel. +39 055941690 - Fax +39 055944328

info@zavaglisanti.com - www.zavaglisanti.com





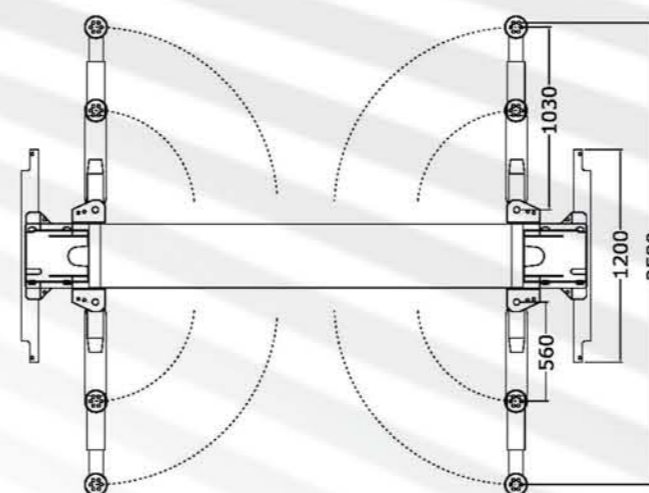
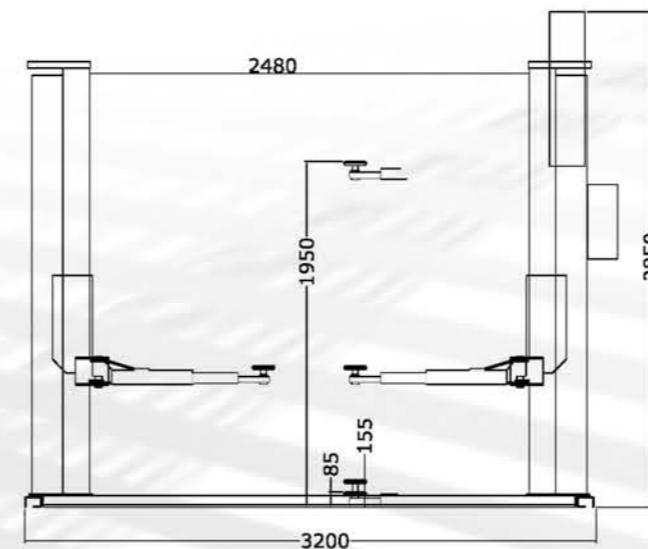

	Z61/3S	Z61M/3S
<b>PORTATA</b> Capacity - Portée - Leistung - Capacidad	<b>Kg 3.500</b>	<b>Kg 3.500</b>
<b>MOTORE</b> Motor - Moteur - Motor - Motor	<b>Kw 1,5</b>	<b>Kw 2,2</b>
<b>VOLTAGGIO</b> Voltage - Spannung - Voltage - Voltaje	<b>V 380</b> <b>50/60 hz</b>	<b>V 220</b> <b>50/60 hz</b>
<b>TEMPO DI SALITA</b> Rasing time - Temps de montée Hubzeit - Tiempo de subida	<b>m/sec. 0,033</b>	<b>m/sec. 0,033</b>
<b>TEMPO DI DISCESA</b> Lowering time - Temps de descente Senkzeit - Tiempo de bajada	<b>m/sec. 0,033</b>	<b>m/sec. 0,033</b>



Z4 OPTIONAL

# Z61/3S

- ▶ Rapidità di sollevamento
- ▶ Maggiore capacità di sollevamento con minore consumo elettrico
- ▶ Minima manutenzione
- ▶ Massima riduzione degli organi di trasmissione
- ▶ Comandi "uomo presente" a 24V
- ▶ Dispositivi di sicurezza elettrici, idraulici e meccanici
- ▶ Bracci telescopici con dispositivo automatico di bloccaggio rotazione
- ▶ Protezione salvapiedi
- ▶ Il sollevatore permette la reversibilità del carico
- ▶ Omologazione CE completa di compatibilità elettromagnetica

- ▶ Fast lifting and lowering
- ▶ Higher lifting with lower electrical consumption
- ▶ Minimum maintenance
- ▶ Maximum reduction of transmission tools
- ▶ "Man on the premises" control, tension 24V
- ▶ Electrical, hydraulic and mechanical safety devices
- ▶ Telescopic arms provided with automatic rotation-stopper
- ▶ Footsaver protection
- ▶ The lift allows reversibility of load
- ▶ CE approved with electromagnetic compatibility

- ▶ Vitesse de montée
- ▶ Portée plus grande avec moindre consommation électrique
- ▶ Manutention minimale
- ▶ Réduction maximale des organes de transmission
- ▶ Commandes de type boutons poussoir à pression contrainte 24V
- ▶ Dispositifs de sécurité électriques, hydrauliques et mécaniques

- ▶ Schneller hebe- und senkvorgang
- ▶ Größere hebekapazität bei gringerem stromverbrauch
- ▶ Minimale wartung
- ▶ Höchste verkleinerung der übertragungselemente
- ▶ Kommando "Bediener anwesend" mit 24V
- ▶ Elektrische, hydraulische und mechanische sicherheitsvorrichtungen

- ▶ Elevación y bajada rápida
- ▶ Capacidad de elevación mayor con menor consumo eléctrico
- ▶ Mínima manutención
- ▶ Máxima reducción de los órganos de transmisión
- ▶ Mandos (botones presión constante) de 24V
- ▶ Dispositivos de seguridad eléctricos, hidráulicos y mecánicos

- ▶ Bras télescopiques avec dispositif automatique de blocage de la rotation
- ▶ Protection pour les pieds
- ▶ L'élevateur permet la réversibilité de la charge
- ▶ Approvation CE avec compatibilité électromagnétique

- ▶ Teleskopierbare tragarme mit automatischer drehblockierung
- ▶ Fußschutz-vorrichtung
- ▶ Die hebehühne ist genehmigt, um die lastreversibilität zu ermöglichen
- ▶ CE-zulassung komplett mit elektromagnetischer kompatibilität

- ▶ Brazos telescopicos con dispositivo automatico de bloqueo de las rotaciones
- ▶ Protector salva pies
- ▶ El elevador permite la reversibilidad de la carga
- ▶ Homologación de tipo CE con compatibilidad electromagnética